



SOLID
TO SUCCEED

SCISSOR LIFT

XG0608C



The print does not belong to the contract, nor a part of the vehicle purchase contract. We reserve the right to revise the product model, parameters, configuration based on the continuous improvement requirements of the product, without prior notice. Pictures are for reference only, and the specific product shall depend on the real product.

XG0608C

Scissor lift

FEATURES

PRODUCTIVITY

- 25% theoretical gradeability
- Battery charge indicator and diagnostic display
- Manual platform lowering valve
- Both platform and ground control panel with emergency stop button
- Auto brake system
- Solid non-marking tires
- Tilt alarm
- Hourmeter record
- Lift and lower alarm
- Horn
- Flashing beacons
- Drive alarm
- Overload alarm

OPTIONS

- Platform working light
- Air-line to platform
- AC power to the platform

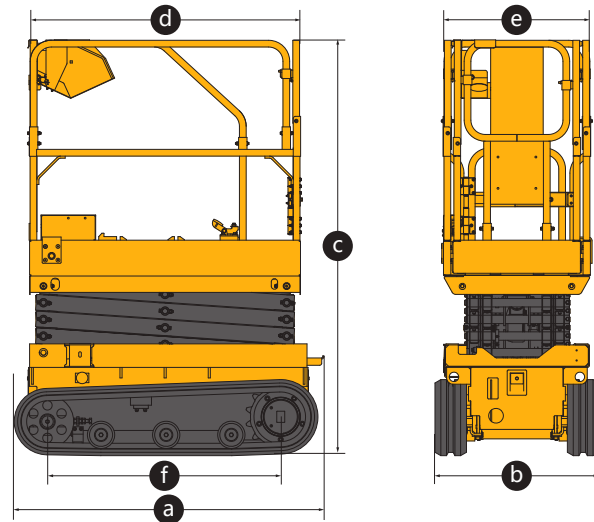

Item	Unit	XG0608C
Lift capacity	kg	200
Lift capacity of auxiliary platform	kg	115
Occupant capacity	-	1
Working height	m	6.5
Platform height	m	4.5
Length of auxiliary platform	mm	550
Ground clearance	mm	70
Turning radius	m	0
Drive motor	kW	0.7
Lift motor	kW	1.3
Drive speed (retracted/extended)	km/h	2/0
Lift/Lower time	s	20-30/19-32
Gradeability	%	25
Tilt alarm	°	1.7
Batteries	V/Ah	24/115
Charger	V/A	24/15
Tires	-	T150×72×44
Weight	kg	800
a Length (without ladder)	mm	1480(1450)
b Width	mm	790
c Height (platform folded)	mm	1990(1625)
d x e Platform size (Length x Width)	mm	1290×700
f Wheelbase	mm	1110

SOLID TO SUCCEED